

SPECTRUM

CAMERA SOLUTIONS

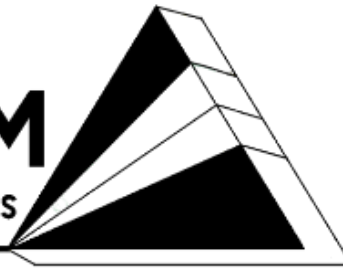

SPECIALIZING IN EXPLOSION PROOF TECHNOLOGY

SPECTRUM “F2XX SERIES” INSTALLATION MANUAL

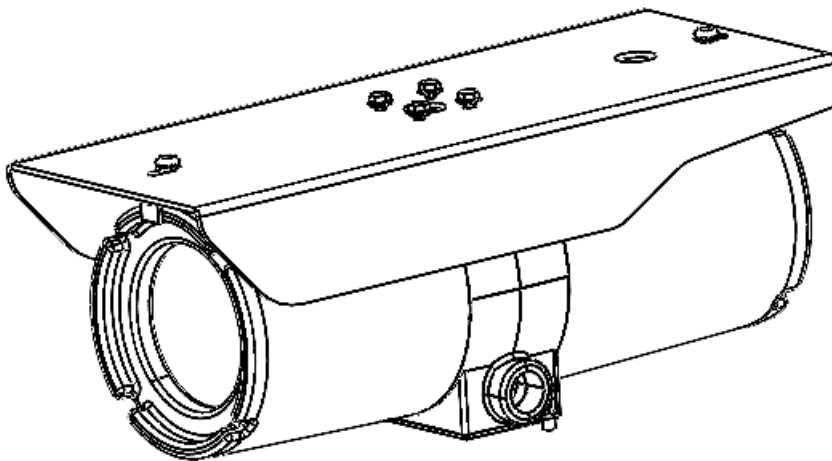

Explosion Proof Network Camera Installation Manual



Release Date: 11/1/2024

Document Name Spectrum F Series INSTALLATION MANUAL

Document Number: 100012292023 rev 0

© Copyright 2021 by Spectrum Camera Solutions LLC All rights reserved

Revision History		
Rev.	Change Description	Date YYYY-MM-DD
0	Initial Release	2024-11-01

Patents, Trademarks, and Proprietary Rights
<p>Manufactured under United States US Patent 9917428 & US Patent D858611</p> <p>All terms mentioned in this manual that are known to be trademarks have been appropriately capitalized. Spectrum Camera Solutions LLC acknowledges all trademark(s) and the rights of the trademark(s) owned by the company referred to herein.</p> <p>The information, data, and illustrations contained in this manual are the property of Spectrum Camera Solutions LLC and may not be reproduced or transmitted in any form or by any means, electronic or mechanical, without the prior written permission of Spectrum Camera Solutions LLC. Doing so will result in Spectrum Camera Solutions LLC exercising maximum possible legal action against all persons and / or organizations involved.</p>

Warranties and Liabilities
<p>Spectrum Camera Solutions LLC makes no representations or warranties with respect to the contents hereof.</p> <p>Further, Spectrum Camera Solutions LLC reserves the right to revise this publication and to make changes in the content hereof, without obligation to notify any person or organization of such revision or changes.</p>

About Spectrum Camera Solutions LLC

Spectrum Camera Solutions manufactures a full range of globally certified Explosion Proof camera systems to monitor any hazardous area. Founded in 2012, Spectrum Camera Solutions has an unparalleled background as a world leader in hazardous area vision systems for process, security, and safety, creating a new range of Explosion Proof cameras based on durable materials, innovative engineering, and operational excellence.

Designed and Manufactured in USA

Spectrum Camera Solutions Explosion Proof Camera products are designed and manufactured in the USA. As a leader with a reputation for creating exciting and reliable hazardous area products, we pride ourselves in delivering outstanding execution from R&D to production as an ISO9001 & ISO14001 certified company.

Award Winning Manufacturer

As a committed leader to excellence and quality, Corporate Vision and Corporate Energy has recognized Spectrum Camera Solutions for our class-leading hazardous area products.

Patented Solutions

Being at the forefront of innovation and safety, Spectrum Camera Solutions is setting the benchmark for engineering excellence. Unique to the market, Spectrum's series of Explosion Proof Cameras utilize the latest technology available in the security camera market integrated into our dual patented housings designed to withstand harsh environmental conditions and certified for hazardous areas.

SPECTRUM CAMERA SOLUTIONS

[+1-281-769-8802](tel:+12817698802)

sales@spectrumcamera.com

[8935 Alameda Genoa Rd. Bldg B, Houston, Texas, USA 77075](https://www.spectrumcamera.com)

“F” Series

Explosion Proof Fixed Camera

The Spectrum Explosion Proof “F-Series” fixed camera product line is designed to the highest national and global industry standards for safe operations in potentially combustible environments. The F-Series is certified to national and international standards for hazardous areas and comes in a marine-ready aluminum enclosure with an IP66 Type 4X rating.

Designed to be installed by a single installer, the F-Series features our quick-bolt mounting brackets/accessories, along with our secondary retention safety lanyard system. Its light-weight body and quick install mounts make F-Series installations easy and cost-effective.

With a temperature range as low as -50C and as high as +90C°, Spectrum Explosion Proof F-Series fixed cameras are suitable for monitoring the most challenging conditions.

- Certified for Class I/II/III, Division 1, IECEx| ATEX Zone 1/21
- Temperature Range: -50C to +90C°
- Marine-Ready Aluminum
- Light Weight: 27 lbs

Note:

This manual is intended to be used for the model specific installation manual. The core information of this manual in regards to installation practices, certifications, Specific conditions of use, and safety shall not be deleted. Additional information regarding voltage supply, network typology connections etc. will be added to and changed accordingly.

Labels and model matrix of models, internal manufacturers etc. may be amended to show only the model of the device being produced and the specific installation manual produced for that model.

Table of Contents

Section	Description	Page
1	Introduction	6
1.1	Intended Audience and Purpose of this Manual	6
1.2	Technical Terms and Abbreviations	6
1.3	Customer Support	6
1.4	Reference Documents	7
1.4.1	Camera Manufacturer	7
1.4.2	International Electrotechnical Commission (IEC) Publications	7
1.4.3	National Fire Protection Association (NFPA) Publications	7
2	Safety	8
2.1	Warning Labels, Symbols, and Notices	8
2.2	Safety Considerations	9
2.3	Important Information	9
2.4	Personnel Qualifications Competence	9
3	Equipment Markings	10
3.1	POE and SFP Label	10
3.2	Wireless Label	10
3.3	Product Specific Markings	11
4	Instructions	12
4.1	Instructions	12
4.2	Safety Considerations	12
4.3	'X' Specific Conditions of Use	12
4.4	Other Certificates - 'X' Specific Conditions of Use	12
4.5	Warning Markings	13
4.6	Detailed Instructions	15
4.6.0	Verification Dossier	15
4.6.1	Procurement, Selection	15
4.6.1.1	Receival	15
4.6.1.2	Preservation	15
4.6.1.3	Handling and Exposure	15
4.6.2	On-site Assembly	16
4.6.2.1	Accessories List – F Series	16
4.6.2.2	BOM (Bill of Materials)	16

Section	Description	Page
4.6.3	Installation and Erection	17
4.6.3.1	Mounting Bracket	17
4.6.3.2	End Cover Removal	17
4.6.4.1	Glands, Connectors, Accessories, Terminations	18
4.6.4.2	Cable Selection	19
4.6.4.3	Electrical Parameters	19
4.6.4.4	Equipment Modifications	19
4.6.4.5	Grounding, Earthing, Bonding, Shielding	19
4.6.5	Adjustment and Parameter Settings	20
4.6.6	QAQC (Quality Assurance & Quality Control)	20
4.6.7	Ex – Initial Inspection	21
4.6.7.1	Documentation	21
4.6.7.2	Specific Inspection Checks	22
4.6.7.3	Sample Documentation	23
4.6.8	Pre-Commissioning & Commissioning	24
4.6.9	Maintenance	24
4.6.10	Troubleshooting	24
4.6.11	Periodic Inspections	25
4.6.11.1	Documentation	25
4.6.11.2	Specific Inspection Checks	25
4.6.11.3	Sample Documentation	26
4.6.12	Repair, Overhaul, and Reclamation	27
4.6.12.1	Servicing	27
4.6.12.2	Cells and Batteries	27
4.6.13	Decommissioning	27
4.6.14	Training	28
4.6.15	Specialty Tools	28

Introduction

This is the Product Manual for the Spectrum Camera Solutions “F” Series Explosion-Proof Fixed Camera.

1.1 | Intended Audience and Purpose of this Manual

This manual is intended as the primary technical reference for Designers, Procurers, Integrators, and Operators of Spectrum Camera Solutions product(s).

Spectrum Camera Solutions assumes that the customer will prepare appropriate documentation for end users of the product. The information required for Ex design, selection, erection, installation, setting-up, commissioning, controlling, troubleshooting, inspection, maintenance, and operations of the Spectrum Camera Solutions product is presented in this manual.

1.2 | Technical Terms and Abbreviations

See the glossary for definitions of potentially unfamiliar terms and abbreviations used throughout this manual. Certain terms do not appear in the manual but are included for general understanding of Spectrum Camera Solutions product(s).

NOTE: The terms “operator” and “user” refer to the person or persons overseeing the operation of the product. In most cases, the product is connected to a system control device that must be programmed to communicate with the product and to respond to alarm messages and other feedback, safely and appropriately, for the intended application.

1.3 | Customer Support

For technical assistance with the installation, operation, troubleshooting, inspection or maintenance of the product, and for technical assistance with issues not covered in this manual:

- Refer to Camera Manufacturer’s Instruction Manual, or
- Contact:

SPECTRUM CAMERA SOLUTIONS

[+1-281-769-8802](tel:+12817698802)

sales@spectrumcamera.com , and

support@spectrumcamera.com

[8935 Almeda Genoa Rd. Bldg B, Houston, Texas, USA
77075](#)

1.4 | Reference Documents

A list of recognized guidelines applicable to use of the camera in Explosive Atmospheres and related systems and technologies is presented here for reference. All users shall be competent with the applicable standards, codes, and regulations of their local or international authorities.

- a. General Arrangement Drawing – Doc #

1.4.1 | Camera Manufacturer

Manufacturer Name:

Model #

Title of Document:





Document # + Rev if applicable

1.4.2 | International Electrotechnical Commission (IEC) Publications

- IEC 60079-10-1 — Explosive atmospheres - Part 10-1: Classification of areas - Explosive gas atmospheres
- IEC 60079-10-2 — Explosive atmospheres - Part 10-2: Classification of areas - Explosive dust atmospheres
- IEC 60079-14 — Explosive atmospheres - Part 14: Electrical installations design, selection, and erection
- IEC 60079-17 — Explosive atmospheres - Part 17: Electrical installations inspection and maintenance
- IEC 60079-19 — Explosive atmospheres - Part 19: Equipment repair, overhaul and reclamation
- IECEx 05 – IEC System for Certification to Standards relating to Equipment for use in Explosive Atmospheres (IECEx System) IECEx Scheme for Certification of Personnel Competence for Explosive Atmospheres

1.4.3 | National Fire Protection Association (NFPA) Publications

- NFPA 497 — Recommended Practice for the Classification of Flammable Liquids, Gases, or Vapors and of Hazardous (Classified) Locations for Electrical Installations in Chemical Process Areas
- NFPA 499 — Recommended Practice for the Classification of Combustible Dusts and of Hazardous (Classified) Locations for Electrical Installations in Chemical Process Areas
- NFPA 70 — National Electrical Code
 - Divisions — Articles 500-504
 - Zones — Articles 505-516

2.1 Warning Labels, Symbols, and Notices		
Symbol	Label	Description
	Ex	This symbol indicates specific conditions of use, schedule of limitations, procedures, instructions, and work methods that shall be followed to ensure that the product cannot cause a flammable gas, vapor, liquid, mist, dust, fiber, or flying atmosphere will not explode when exposed to any of the >13 potential sources of ignition.
	CAUTION:	Consists of conditions, practices, or procedures that must be observed to prevent personal injury and/or equipment damage.
	WARNING:	Risk of electric shock or high temperature parts may result in injury if proper precautions are not taken.
	NOTE:	Emphasizes important or essential information.
	GROUND / EARTH:	This symbol identifies a location for ground / bond . Earth equipment to protective earth. As a warning, it also indicates that grounding / bonding / earthing is required for safe operation of the equipment.
<p>NOTE: The symbols are used throughout this manual to alert users to potential hazards or important information. <i>Failure to adhere to these warnings may lead to negative impacts on health, safety, environmental, and equipment, whereby, this shall result in the null & void of all warranties and legal responsibilities of Manufacturer(s).</i></p>		

2.2 | Safety Considerations

The equipment supplied by Spectrum Camera Solutions is designed to comply with relevant safety standards and to prevent the ignition of potential explosive atmospheres. The equipment and protective systems are designed and manufactured to ensure safe operation.

2.3 | Important Information



The product, systems, and equipment must be designed, selected, installed, commissioned, inspected, and maintained by qualified, competent, and authorized personnel only.

Qualified personnel shall have detailed knowledge concerning electrical equipment for use in potentially explosive areas containing gas and/or dust. Qualified personnel must have knowledge regarding the types of explosion protection. This equipment is intended to be used in Zone 1, 2, 21, and 22 for groups IIB+H2 and IIC with temperature classes T4/125°C, T5/T100°C or T6/T85°C, it is necessary to verify if this equipment is in accordance with the hazardous area classification drawings and reports where it is installed.

Note: Hazardous Area Classification must be performed by a qualified and competent Engineer. Failure to do so or any non-conformances to applicable standards, codes, or regulations shall null & void all warranties, liabilities, and responsibilities of the manufacturer.

2.4 | Personnel Qualifications Competence

Personnel responsible for design, selection, installation, commissioning, inspection, and maintenance of the equipment described in this manual:

- ✓ Should attend Integrator Training from a Spectrum Camera Solutions approved RTP (Recognized Training Provider);
- ✓ Read, understand, and comply with the instructions presented throughout this manual;
- ✓ Read the manual to understand the potential hazards associated with the systems or equipment;
- ✓ Retain this manual for future reference;
- ✓ Read, understand, and comply with the instructions presented throughout the associated Camera Manufacturer's Manuals;
- ✓ Fully understand and comply with all applicable local safety standards, by-laws, codes and regulations.
- ✓ Have the necessary IECEx Certificate Personnel of Competency (CoPC) with the relevant Ex Units applicable to their role & position to IECEx OD 504, or equivalent
 - <https://www.iecex.com/>
 - <https://www.iecex-certs.com/#/home>
 - If applicable, National Deviations shall be complied with.
 - If applicable, Equivalent Personnel Certification is acceptable to a scheme that is ISO 17024 approved, specific to the region of installation and Ex Certification Scheme.

3 | Equipment Markings

3.1 | POE and SFP Models



SPECIALIZING IN EXPLOSION PROOF TECHNOLOGY
8935 ALMEDA GENOA RD. HOUSTON, TEXAS 77075 USA

SERIAL: TIME-MN-DY-YEAR



MADE IN USA



MODEL: F2AA-BB-CC-EE-FF
POE INPUT: IEEE 802.3xx, X.X W;
VAC INPUT: XXX VAC, X.X W, 50/60 Hz;
VDC INPUT: XX VDC, X.X W;

ENTRY	DEVICE ENTRY
3/4" NPT	
M25	

US/Canada: Class I Division 1 Groups BCD [SEE TABLE 1](#), Type 4X, IP66

Class II/III Division 1 Groups EFG [SEE TABLE 2](#), Type 4X, IP66

Class I, Zone 1, AEx/Ex db IIB+H2 Gb [SEE TABLE 1](#), Type 4X, IP66

Zone 21, AEx/Ex tb IIIC Db [SEE TABLE 3](#), Type 4X, IP66

 II 2 G Ex db IIB+H2 Gb [SEE TABLE 1](#), IP66

 II 2 D Ex tb IIIC Db [SEE TABLE 1](#), IP66

TABLE 1	
'T' CODE	AMB TEMP RANGE
T6/T85°C	-50°C TO +50°C
T5/T100°C	-50°C TO +65°C
T4/T125°C	-50°C TO +90°C

TABLE 2		TABLE 3	
'T' CODE	AMB TEMP RANGE	'T' CODE	AMB TEMP RANGE
T6	-50°C TO +48°C	T87°C	-50°C TO +50°C
T5	-50°C TO +63°C	T102°C	-50°C TO +65°C
T4	-50°C TO +90°C	T127°C	-50°C TO +90°C

CERT NO. FM24US0209X & FM24CA0056XIECEx FMG 24.0028X, & FM24ATEX0026X

WARNING: DO NOT OPEN WHEN ENERGIZED OR WHEN AN EXPLOSIVE ATMOSPHERE MAY BE PRESENT. Install seal within 18 inches.

WARNING: POTENTIAL ELECTROSTATIC CHARGING HAZARD – SEE INSTRUCTION **NOTE:** FOR BATTERY REPLACEMENT DETAILS- SEE INSTRUCTION

AVERTISSEMENT: NE PAS OUVRIR LORSQU'ENERGISE OU QUAND UNE ATMOSPHERE EXPLOSIVE PEUT ETRE PRESENTE. Les joints de fermeture sont obligatoires dans une distance de 18 pouces.

AVERTISSEMENT - RISQUE DE CHARGE ÉLECTROSTATIQUE POTENTIEL - VOIR LES INSTRUCTIONS. REMARQUE : POUR LES DÉTAILS SUR LE REMPLACEMENT DE LA BATTERIE, VOIR LES INSTRUCTIONS

3.2 | Wireless Models



SPECIALIZING IN EXPLOSION PROOF TECHNOLOGY
8935 ALMEDA GENOA RD. HOUSTON, TEXAS 77075 USA

SERIAL: TIME-MN-DY-YEAR



MADE IN USA



MODEL: F2AA-BB-CC-EE-FF
POE INPUT: IEEE 802.3xx, X.X W;
VAC INPUT: XXX VAC, X.X W, 50/60 Hz;
VDC INPUT: XX VDC, X.X W;

ENTRY	DEVICE ENTRY
3/4" NPT	
M25	

US/Canada: Class I Division 1 Groups BCD [SEE TABLE 1](#), Type 4X, IP66

Class II/III Division 1 Groups EFG [SEE TABLE 2](#), Type 4X, IP66

Class I, Zone 1, AEx/Ex db mb [ia Ga] IIB+H2 Gb [SEE TABLE 1](#), Type 4X, IP66

Zone 21, AEx/Ex mb tb [ia Da] IIIC Db [SEE TABLE 3](#), Type 4X, IP66

 II 2 (1) G Ex db mb [ia Ga] IIB+H2 Gb [SEE TABLE 1](#), IP66

 II 2 (1) D Ex mb tb [ia Da] IIIC Db [SEE TABLE 1](#), IP66

TABLE 1	
'T' CODE	AMB TEMP RANGE
T6/T85°C	-40°C TO +50°C
T5/T100°C	-40°C TO +65°C
T4/T105°C	-40°C TO +70°C
T4/T120°C	-40°C TO +85°C

TABLE 2		TABLE 3	
'T' CODE	AMB TEMP RANGE	'T' CODE	AMB TEMP RANGE
T6	-40°C TO +48°C	T87°C	-40°C TO +50°C
T5	-40°C TO +63°C	T102°C	-40°C TO +65°C
T4	-40°C TO +70°C	T107°C	-40°C TO +70°C
T4	-40°C TO +85°C	T122°C	-40°C TO +85°C

CERT NO. FM24US0209X & FM24CA0056XIECEx FMG 24.0028X, & FM24ATEX0026X

WARNING: DO NOT OPEN WHEN ENERGIZED OR WHEN AN EXPLOSIVE ATMOSPHERE MAY BE PRESENT. Install seal within 18 inches.

WARNING: POTENTIAL ELECTROSTATIC CHARGING HAZARD – SEE INSTRUCTION **NOTE:** FOR BATTERY REPLACEMENT DETAILS- SEE INSTRUCTION

AVERTISSEMENT: NE PAS OUVRIR LORSQU'ENERGISE OU QUAND UNE ATMOSPHERE EXPLOSIVE PEUT ETRE PRESENTE. Les joints de fermeture sont obligatoires dans une distance de 18 pouces.

AVERTISSEMENT - RISQUE DE CHARGE ÉLECTROSTATIQUE POTENTIEL - VOIR LES INSTRUCTIONS. REMARQUE : POUR LES DÉTAILS SUR LE REMPLACEMENT DE LA BATTERIE, VOIR LES INSTRUCTIONS

3.3 | Product Specific Markings

Please refer to General Arrangement Drawing for product specific Ex Equipment Markings and Warning Markings

DETAIL 1
GENERAL ARRANGEMENT

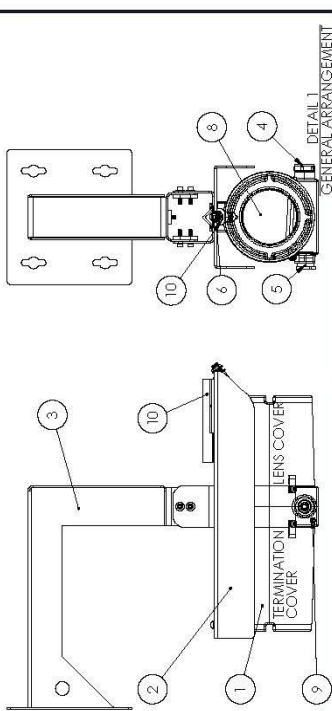

DETAIL 2
TERMINATION GUIDE

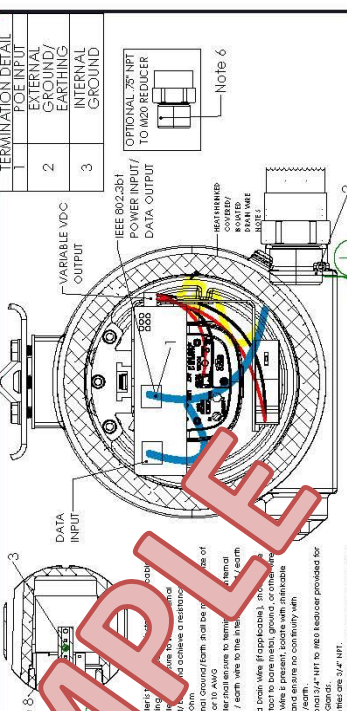

DETAIL 3
CONDUIT ENTRY

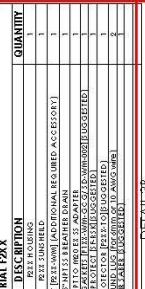

DETAIL 4
MARKINGS

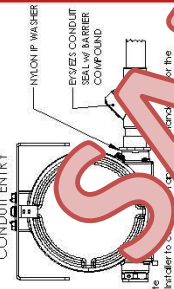

DETAIL 5
ELECTRICAL PARAMETERS

Power Option 1	Power Option 2
VOLTS WATTS	VOLTS WATTS
HEATER ELECTRICAL PARAMETERS	VOLTS WATTS

ITEM NUMBER

ITEM NUMBER	DESCRIPTION	QUANTITY
1	R322 2.5" SINGLED	1
2	FLAT WALL MOUNT ASSEMBLY (R322-1MM) (PERSONAL PROTECTIVE EQUIPMENT REQUIRED ACCESSORY)	1
3	TERMINATION COVER	1
4	LENS COVER	1
5	TERMINATION COVER	1
6	TERMINATION COVER	1
7	TERMINATION COVER	1
8	TERMINATION COVER	1
9	TERMINATION COVER	1
10	TERMINATION COVER	1

NOTE:

1. Installer to comply with applicable standards for the Barrier Compound (see Barrier Compound section of the Barrier Compound manual).
2. INSTALL SEAL WITHIN 18 inches. For Zones, install seal at entry.

NOTE:

1. Installer to ensure correct selection and application of Barrier Compound for the correct selection and application of Barrier Compound. Refer to the Barrier Compound manual for more information.
2. INSTALL SEAL WITHIN 18 inches. For Zones, install seal at entry.

NOTE 8:

1. The camera is designed to be installed in a hazardous area. The camera is designed to be installed in a hazardous area.
2. The camera is designed to be installed in a hazardous area. The camera is designed to be installed in a hazardous area.
3. External Grounding must be provided for the camera. The camera is designed to be installed in a hazardous area.
4. The camera is designed to be installed in a hazardous area. The camera is designed to be installed in a hazardous area.
5. The camera is designed to be installed in a hazardous area. The camera is designed to be installed in a hazardous area.
6. The camera is designed to be installed in a hazardous area. The camera is designed to be installed in a hazardous area.
7. The camera is designed to be installed in a hazardous area. The camera is designed to be installed in a hazardous area.
8. The camera is designed to be installed in a hazardous area. The camera is designed to be installed in a hazardous area.

OPTIONAL 75T NPT TO M20 REDUCER

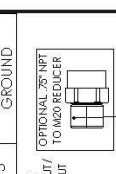

OPTIONAL 802-384 POWER INPUT TO M20 REDUCER



OPTIONAL 802-384 DATA OUTPUT



OPTIONAL 75T NPT TO M20 REDUCER



OPTIONAL 802-384 POWER INPUT TO M20 REDUCER



OPTIONAL 802-384 DATA OUTPUT



OPTIONAL 75T NPT TO M20 REDUCER



OPTIONAL 802-384 POWER INPUT TO M20 REDUCER



OPTIONAL 802-384 DATA OUTPUT

OPTIONAL 75T NPT TO M20 REDUCER

OPTIONAL 802-384 POWER INPUT TO M20 REDUCER

OPTIONAL 802-384 DATA OUTPUT

OPTIONAL 75T NPT TO M20 REDUCER

OPTIONAL 802-384 POWER INPUT TO M20 REDUCER

OPTIONAL 802-384 DATA OUTPUT

OPTIONAL 75T NPT TO M20 REDUCER

OPTIONAL 802-384 POWER INPUT TO M20 REDUCER

OPTIONAL 802-384 DATA OUTPUT

OPTIONAL 75T NPT TO M20 REDUCER

OPTIONAL 802-384 POWER INPUT TO M20 REDUCER

OPTIONAL 802-384 DATA OUTPUT

OPTIONAL 75T NPT TO M20 REDUCER

OPTIONAL 802-384 POWER INPUT TO M20 REDUCER

OPTIONAL 802-384 DATA OUTPUT

OPTIONAL 75T NPT TO M20 REDUCER

OPTIONAL 802-384 POWER INPUT TO M20 REDUCER

OPTIONAL 802-384 DATA OUTPUT

OPTIONAL 75T NPT TO M20 REDUCER

OPTIONAL 802-384 POWER INPUT TO M20 REDUCER

OPTIONAL 802-384 DATA OUTPUT

OPTIONAL 75T NPT TO M20 REDUCER

OPTIONAL 802-384 POWER INPUT TO M20 REDUCER

OPTIONAL 802-384 DATA OUTPUT

OPTIONAL 75T NPT TO M20 REDUCER

OPTIONAL 802-384 POWER INPUT TO M20 REDUCER

OPTIONAL 802-384 DATA OUTPUT

OPTIONAL 75T NPT TO M20 REDUCER

OPTIONAL 802-384 POWER INPUT TO M20 REDUCER

OPTIONAL 802-384 DATA OUTPUT

OPTIONAL 75T NPT TO M20 REDUCER

OPTIONAL 802-384 POWER INPUT TO M20 REDUCER

OPTIONAL 802-384 DATA OUTPUT

OPTIONAL 75T NPT TO M20 REDUCER

OPTIONAL 802-384 POWER INPUT TO M20 REDUCER

OPTIONAL 802-384 DATA OUTPUT

OPTIONAL 75T NPT TO M20 REDUCER

OPTIONAL 802-384 POWER INPUT TO M20 REDUCER

OPTIONAL 802-384 DATA OUTPUT

OPTIONAL 75T NPT TO M20 REDUCER

OPTIONAL 802-384 POWER INPUT TO M20 REDUCER

OPTIONAL 802-384 DATA OUTPUT

OPTIONAL 75T NPT TO M20 REDUCER

OPTIONAL 802-384 POWER INPUT TO M20 REDUCER

OPTIONAL 802-384 DATA OUTPUT

OPTIONAL 75T NPT TO M20 REDUCER

OPTIONAL 802-384 POWER INPUT TO M20 REDUCER

OPTIONAL 802-384 DATA OUTPUT

OPTIONAL 75T NPT TO M20 REDUCER

OPTIONAL 802-384 POWER INPUT TO M20 REDUCER

OPTIONAL 802-384 DATA OUTPUT

OPTIONAL 75T NPT TO M20 REDUCER

OPTIONAL 802-384 POWER INPUT TO M20 REDUCER

OPTIONAL 802-384 DATA OUTPUT

OPTIONAL 75T NPT TO M20 REDUCER

OPTIONAL 802-384 POWER INPUT TO M20 REDUCER

OPTIONAL 802-384 DATA OUTPUT

OPTIONAL 75T NPT TO M20 REDUCER

OPTIONAL 802-384 POWER INPUT TO M20 REDUCER

OPTIONAL 802-384 DATA OUTPUT

OPTIONAL 75T NPT TO M20 REDUCER

OPTIONAL 802-384 POWER INPUT TO M20 REDUCER

OPTIONAL 802-384 DATA OUTPUT

OPTIONAL 75T NPT TO M20 REDUCER

OPTIONAL 802-384 POWER INPUT TO M20 REDUCER

OPTIONAL 802-384 DATA OUTPUT

OPTIONAL 75T NPT TO M20 REDUCER

OPTIONAL 802-384 POWER INPUT TO M20 REDUCER

OPTIONAL 802-384 DATA OUTPUT

OPTIONAL 75T NPT TO M20 REDUCER

OPTIONAL 802-384 POWER INPUT TO M20 REDUCER

OPTIONAL 802-384 DATA OUTPUT

OPTIONAL 75T NPT TO M20 REDUCER

OPTIONAL 802-384 POWER INPUT TO M20 REDUCER

OPTIONAL 802-384 DATA OUTPUT

OPTIONAL 75T NPT TO M20 REDUCER

OPTIONAL 802-384 POWER INPUT TO M20 REDUCER

OPTIONAL 802-384 DATA OUTPUT

OPTIONAL 75T NPT TO M20 REDUCER

OPTIONAL 802-384 POWER INPUT TO M20 REDUCER

OPTIONAL 802-384 DATA OUTPUT

OPTIONAL 75T NPT TO M20 REDUCER

OPTIONAL 802-384 POWER INPUT TO M20 REDUCER

OPTIONAL 802-384 DATA OUTPUT

OPTIONAL 75T NPT TO M20 REDUCER

OPTIONAL 802-384 POWER INPUT TO M20 REDUCER

OPTIONAL 802-384 DATA OUTPUT

OPTIONAL 75T NPT TO M20 REDUCER

OPTIONAL 802-384 POWER INPUT TO M20 REDUCER

OPTIONAL 802-384 DATA OUTPUT

OPTIONAL 75T NPT TO M20 REDUCER

OPTIONAL 802-384 POWER INPUT TO M20 REDUCER

OPTIONAL 802-384 DATA OUTPUT

OPTIONAL 75T NPT TO M20 REDUCER

OPTIONAL 802-384 POWER INPUT TO M20 REDUCER

OPTIONAL 802-384 DATA OUTPUT

OPTIONAL 75T NPT TO M20 REDUCER

OPTIONAL 802-384 POWER INPUT TO M20 REDUCER

OPTIONAL 802-384 DATA OUTPUT

OPTIONAL 75T NPT TO M20 REDUCER

OPTIONAL 802-384 POWER INPUT TO M20 REDUCER

OPTIONAL 802-384 DATA OUTPUT

OPTIONAL 75T NPT TO M20 REDUCER

OPTIONAL 802-384 POWER INPUT TO M20 REDUCER

OPTIONAL 802-384 DATA OUTPUT

OPTIONAL 75T NPT TO M20 REDUCER

OPTIONAL 802-384 POWER INPUT TO M20 REDUCER

OPTIONAL 802-384 DATA OUTPUT

OPTIONAL 75T NPT TO M20 REDUCER

OPTIONAL 802-384 POWER INPUT TO M20 REDUCER

OPTIONAL 802-384 DATA OUTPUT

OPTIONAL 75T NPT TO M20 REDUCER

OPTIONAL 802-384 POWER INPUT TO M20 REDUCER

OPTIONAL 802-384 DATA OUTPUT

OPTIONAL 75T NPT TO M20 REDUCER

OPTIONAL 802-384 POWER INPUT TO M20 REDUCER

OPTIONAL 802-384 DATA OUTPUT

OPTIONAL 75T NPT TO M20 REDUCER

OPTIONAL 802-384 POWER INPUT TO M20 REDUCER

OPTIONAL 802-384 DATA OUTPUT

OPTIONAL 75T NPT TO M20 REDUCER

OPTIONAL 802-384 POWER INPUT TO M20 REDUCER

OPTIONAL 802-384 DATA OUTPUT

OPTIONAL 75T NPT TO M20 REDUCER

OPTIONAL 802-384 POWER INPUT TO M20 REDUCER

OPTIONAL 802-384 DATA OUTPUT

OPTIONAL 75T NPT TO M20 REDUCER

OPTIONAL 802-384 POWER INPUT TO M20 REDUCER

OPTIONAL 802-384 DATA OUTPUT

OPTIONAL 75T NPT TO M20 REDUCER

OPTIONAL 802-384 POWER INPUT TO M20 REDUCER

OPTIONAL 802-384 DATA OUTPUT

OPTIONAL 75T NPT TO M20 REDUCER

OPTIONAL 802-384 POWER INPUT TO M20 REDUCER

OPTIONAL 802-384 DATA OUTPUT

OPTIONAL 75T NPT TO M20 REDUCER

OPTIONAL 802-384 POWER INPUT TO M20 REDUCER

OPTIONAL 802-384 DATA OUTPUT

OPTIONAL 75T NPT TO M20 REDUCER

OPTIONAL 802-384 POWER INPUT TO M20 REDUCER

OPTIONAL 802-384 DATA OUTPUT

OPTIONAL 75T NPT TO M20 REDUCER

OPTIONAL 802-384 POWER INPUT TO M20 REDUCER

OPTIONAL 802-384 DATA OUTPUT

OPTIONAL 75T NPT TO M20 REDUCER

OPTIONAL 802-384 POWER INPUT TO M20 REDUCER

OPTIONAL 802-384 DATA OUTPUT

OPTIONAL 75T NPT TO M20 REDUCER

OPTIONAL 802-384 POWER INPUT TO M20 REDUCER

OPTIONAL 802-384 DATA OUTPUT

OPTIONAL 75T NPT TO M20 REDUCER

OPTIONAL 802-384 POWER INPUT TO M20 REDUCER

OPTIONAL 802-384 DATA OUTPUT

OPTIONAL 75T NPT TO M20 REDUCER

4.1 | Instructions

This manual is intended be reviewed and used together with the manufacturer’s manual for the internal equipment, and the Ex-Certificate requirements, conditions of use, & schedule of limitations.

Note: In the event of a conflict between the requirements of this “Explosion Proof” installation manual, the internal equipment manufacturer’s manual, and the Ex-Certificate, then, the safety, design, selection, installation, commissioning, maintenance, inspection, and operation instructions & procedures described in this manual shall take precedence, with the Ex-Certificate holding ultimate precedence.

Note 2: Refer to General Arrangement Drawing



4.2 | Safety Considerations

The entire 4 | Instructions section must be read and fully understood by all person(s) involved in design, selection, installation, commissioning, maintenance, inspection, and operations of this equipment. This manual is designed to aid personnel in the systems described.

Personnel must consider all actions and procedures for potential hazards or conditions that may not have been anticipated in the written procedures. If a procedure cannot be performed safely, it must not be performed until appropriate actions can be taken to ensure the safety of equipment and personnel. Site specific requirements must also be adhered to.



4.3 | ‘X’ Specific Conditions of Use

1. The flameproof joints of the equipment are not intended to be repaired. Consult the manufacturer if dimensional information on the flameproof joints is necessary.
2. Follow the manufacturer's instructions to reduce the potential of an electrostatic charging hazard on the surface of the equipment in Group II and III environments.
3. The equipment within the enclosure may be placed in any arrangement provided that an area of at least 20% of each cross-sectional area remains free to permit unimpeded gas flow and, therefore, unrestricted development of an explosion. Separate relief areas may be aggregated provided each area has a minimum dimension, in any direction, of 12.5 mm.



4.4 | Other Certificates - ‘X’ Specific Conditions of Use

Refer to all ATEX, CSA, IECEx, NEC, NFPA and FM certificates for any Specific Conditions of Use. If the sign “X” is placed after the certificate number, it indicates that the equipment or protective system is subject to Specific conditions for safe use specified in the schedule of the certificate.



Note - Instructions

Review all material and safety information in this manual and install in accordance with this document and all other applicable ATEX, CSA, IECEx, NEC, NFPA70 Installation Methods and FM and National standards.

4.5 | Warning Markings



- Do not open when an Explosive Atmosphere may be present
- Potential electrostatic discharge: See instructions
- Install Seal within 18 inches; (with an Ex-Certified barrier gland or conduit seal with separate certificate)
- Cable gland, cable and/or wiring in conduit which will be used, is required to be rated to at least 10°C higher than maximum ambient temperature of the installation area.



Warning



Failure to follow appropriate instructions, safety procedures, or appropriate use of the equipment described in this manual can lead to injury of personnel or equipment damage.

Warning – Live Maintenance or Live Inspection



WARNING – DO NOT OPEN WHEN AN EXPLOSIVE ATMOSPHERE IS PRESENT. Live maintenance or detailed inspections shall not be done. Sufficient time shall be allowed for hot components to cool down before conducting maintenance or detail inspections. Be aware after de-energization internal components may still pose as a potential source of ignition, electrostatic discharge, or electrical shock risk.

Warning – Electrical Safety



Any additional safety and operating measures that are required must be determined by and followed by personnel performing work on the electrical equipment. All site-specific electrical safety considerations must be followed.

NOTE- For US and Canada Zone installations the internal Ground must be utilized, and external grounding is optional.

Warning – Anti-Static (ESD – Electrostatic Discharge)



Users and Operators must use anti-static PPE (clothes, boots, etc) to EN 1149-5 STANDARD FOR PROTECTION AGAINST EXPLOSION HAZARDS or equivalent standard. Failure to do so may cause a potential source of ignition or damage to components.

Warning – PPE (Personal Protection Equipment)



Slip resistant gloves and protective eyewear (glasses with side shields or goggles as appropriate) should be worn when performing all activates.

Also, refer to Warning – Anti-Static (ESD – Electrostatic Discharge).

Warning – Repair, Overhaul, Reclamation, Replacements



Unit must be returned to manufacturer for any repairs, overhaul, reclamation, replacement of parts. Customer are not permitted to perform any of these activities or open the main enclosure of the camera housing. Doing so will null & void all warranties and Ex-Certification(s)

Customer are not permitted to perform any of these activities or open the main enclosure of the camera housing. Doing so will null & void all warranties and Ex-Certification(s)

Warning – Main Housing (Equipment Compartment)



WARNING – DO NOT OPEN WHEN AN EXPLOSIVE ATMOSPHERE IS PRESENT. Live maintenance or detailed inspections shall not be done. Sufficient time shall be allowed for hot components to cool down before conducting maintenance or detail inspections. Be aware after de-energization internal components may still pose as a potential source of ignition, electrostatic discharge, or electrical shock risk.



4.6.0 | Verification Dossier

If applicable a Verification Dossier should be prepared by User or Operator for every installation and shall be kept on the premises or stores in another location.

In order to correctly install or extend an existing installation, all information listed in IEC 60079-14 Clause 4.2 and IEC 60079-17 Clause 4.4, additional to that required in non-hazardous area, is required as part of the verification dossier, where applicable.

All documentation, evidence of training, installation, inspections, and maintenance shall be documented and found within the Verified Dossier.

4.6.1 | Procurement, Selection

The "F" Series IP cameras operate from a variety of power options including IEEE compliant POE devices, VAC and VDC power sources. Correct selection of the model for system installation is the responsibility of the User or Operator.

4.6.1.1 | Receival

Upon receival of the "F" Series IP Camera, the User or Operator is responsible for conducting an initial detailed inspection to ensure correct selection, no missing components or documentation, and absence of any damages.

4.6.1.2 | Preservation

It is the responsibility of the User or Operator to maintain ingress protection and implement approved preservation methods upon receival of the "F" Series IP Camera, including each stage of installation, operations, maintenance, and operations.

Preservation methods shall comply with site specifications and applicable standards, and to ensure not to invalidate the Ex protection method(s). Equipment shall be stored in a dry, ventilated, climate-controlled environment.

4.6.1.3 | Handling and Exposure

It is the responsibility of the User or Operator to ensure no exposure of the equipment to impacts, shocks, heavy pressure, temperature swing, chemicals, caustic agents, or aerosol cleaners.

Cleaning or wiping of the equipment shall ONLY be done with a clean, damp cloth with water and mild soap. No industrial, alcoholic, ketone, or similar cleaners shall be used.

4.6.2 | On-site Assembly



User or Operator must ensure to confirm receipt and use of correct accessories with the instruction and technical specifications of the equipment to be installed. These may be sourced from Spectrum Camera Solutions LLC (Sec 5.6.2.1) or a third party.

4.6.2.1 | Accessories List – F Series

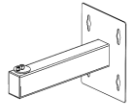
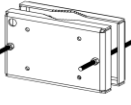
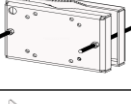
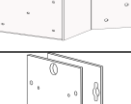
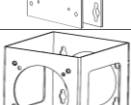
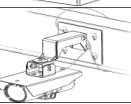
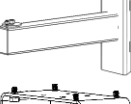
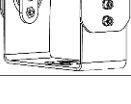
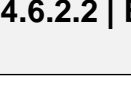
	F2XX-WM: WALL MOUNT
	SD-PM: POLE MOUNT
	SD-PM XL: XL POLE MOUNT
	SD-CM: CORNER MOUNT
	SD-VM: VIBRATION MOUNT
	SD-UM: UNIVERSAL MOUNT
	SF-RSK: RELIABLE SECURING KIT
	F2XX-PM: DIRECT TO POLE MOUNT
	F2XX-GM: KNUCKLE ASSEMBLY



4.6.2.2 | BOM (Bill of Materials)

Refer to General Arrangement Drawing



4.6.3 | Installation and Erection

The installation must be in accordance with IEC/EN 60079-14 and/or in accordance with national deviations / requirements.



Installation of equipment shall be done with hand tools. Excessive force, such as power tools, shall not be used specifically to avoid damage of equipment.

Equipment shall be installed on secure, stable, mechanically robust and complete surfaces / assemblies.

Integrators / Installers shall be qualified (trained and competent) to install electrical equipment in explosive atmospheres and Spectrum Camera Solutions products.

Installations should be done to site approved engineered drawings and documented (inspection test reports).

4.6.3.1 | Mounting Bracket

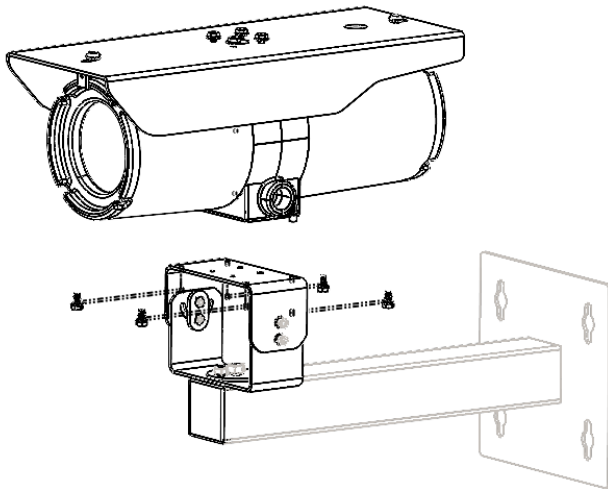
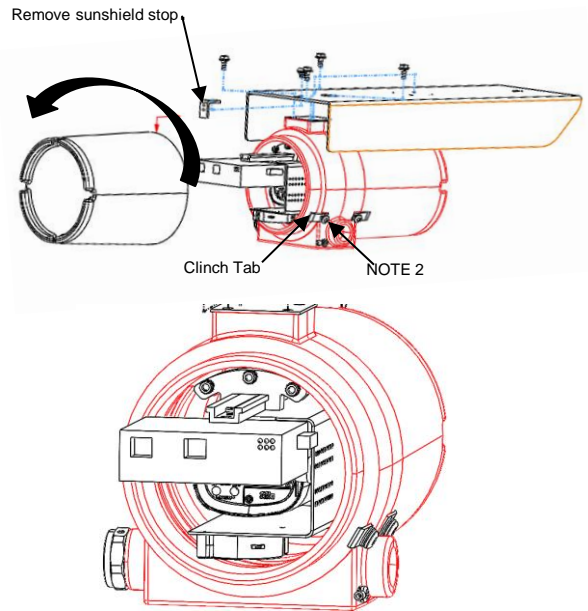

Figure 1. wall bracket installation

1. Use 7/16 wrench remove hex bolts from housing and sunshield.
2. Make sure threads on camera and 1/4"-20 bolts are free of dirt and debris. Place mount on camera and align holes and tighten bolts.
Note: add anti-seize for offshore installations.
3. Attach the camera with wall mount to mounting surface. Use only installation methods and materials capable of supporting four times the maximum specified load of the system.

4.6.3.2 | End Cover Removal



1. Remove the safety stop from rear of sunshield.
2. Loosen screw on the clinch tab, unscrew the end cover.
3. Proceed to Section 5.6.4

4.6.4.1 | Glands, Connectors, Accessories, Terminations



Refer to General Arrangement Drawing

Cable Glands

Cable gland selection shall comply with require Ex protection technique, cable type, cable armour, and other requirements.

The cable entry must be made-off and installed correctly as per Ex-Certificate and manufacturer's instructions in order not to alter the specific properties of terminal housing compartment. **All entries are 3/4" NPT OR M25-1.5mm.**

To maintain the ingress protection level of the equipment, all cable glands shall require use of IP (Ingress Protection) washers or o-ring, excluding fiber type. The use of gland "Shrouds" should be avoided, as they gather condensation and cause corrosion.

The connection to the external circuits must be done by cable glands or conduit fittings covered by a separate Ex-certificate(s). If a cable gland is not used or an entry is open, the entry must be closed by a stopping plug covered by a separate ex-certificate. This equipment can be used with different voltage and power, the nominal parameters are specified in the manual.

Terminations – Refer to General Arrangement Drawing

Terminations shall be made with provided terminals.

The use of core-end sleeves / bootlace crimps / ferrules are approved for use with stranded cores. Creepage and clearance distance requirements shall be maintained.

Fiber-Optic terminations shall be according cable manufacturer's instructions.



4.6.4.2 | Cable Selection

Electrical Cable:

- Cable(s) must be tested and certified for temperatures 10°C higher than the maximum ambient temperature of the installation area.
- Shall be suitable for the division / zone in which the cable is installed in.
- Shall be Fire Resistant and/or Fire Retardant specific to standards and site-specific requirements.
- Cable shall provide sufficient sealing to avoid the passage of gas and flame propagation between the cores and other layers. IEC 60079-14 Annex E test compliance can verify a cables compliance. (IEC Standard)
- Cables <3 meters in lengths shall require sealing means, e.g. barrier gland. (IEC Standard)

Fiber-Optic Cable: Use a suitably certified cable and internal connections shall comply with requirements of EN/IEC 60079-15.

4.6.4.3 | Electrical Parameters

Refer to General Arrangement Drawing

4.6.4.4 | Equipment Modifications

Modifications shall not be done. The equipment must be installed and used in strict accordance with the instructions given in this instruction manual

- This equipment contains no user-serviceable components.
- Unauthorized equipment changes or modifications will invalidate all applicable regulatory certifications and approvals.

4.6.4.5 | Grounding, Earthing, Bonding, Shielding

Refer to General Arrangement Drawing

4.6.5 | Adjustment and Parameter Settings

Any internal heating devices, fans, or devices that may be adjusted shall be done to manufacturer's instructions. Refer to camera manufacturer's manual in conjunction with this manual.

4.6.6 | QAQC (Quality Assurance & Quality Control)

The following electrical and safety checks shall be made and documented (inspection test reports) before initial Ex inspection, if applicable:

- Cable / core(s) continuity and polarity checks
- Fiber-optic continuity checks (if applicable)
- Insulation resistance checks of cables and core(s) insulation
- Equipotential Bond resistance checks (< 1 Ohm)
- Earthing / Grounding resistance checks (< 1 Ohm)
- Fault-loop impedance checks
- Safety Device setting checks
- Safety Device operations setting(s) checks

Testers shall be trained and competent to test electrical equipment in explosive atmospheres, local electrical codes and regulations

Note 1: Insulation resistance checks shall not be made with completed (landed) terminations, or internal components may be damaged.

Note 2: Such testing shall not be done within Hazardous Areas / Explosive Atmospheres, or without the direct approval of responsibly party with required isolations, permit systems, and gas detections measures in place.

4.6.7 | Ex – Initial Inspection

Equipment shall be inspected before handover for Pre-Commissioning or Operations. The Type of Inspection shall be “Initial Inspection”, with the QAQC test reports available and complete.

Initial Inspection

Inspection of all electrical equipment, systems, and installations before they are brought into service / energized.

Detailed Inspection:

Inspection which encompasses those aspects covered by a close inspection and, in addition, identifies those defects, such as loose terminations, which will only be apparent by opening the enclosure, and/or using, where necessary, tools and test equipment.

Close Inspection:

Inspection which encompasses those aspects covered by a visual inspection and, in addition, identifies those defects, such as loose bolts, which will be apparent only by the use of access equipment

EXAMPLE Steps or ladders, (where necessary), and tools.

Note 1 to entry: Close inspections do not normally require the enclosure to be opened, or the equipment to be deenergized.

Visual Inspection:

Inspection which identifies, without the use of access equipment or tools, those defects, such as missing bolts, which will be apparent to the eye.

Inspectors should be qualified to inspect electrical equipment in explosive atmospheres and Spectrum Camera Solutions products.

4.6.7.1 | Documentation

Inspections should be documented via inspection test reports, with support of pictures.

Documentation formats shall comply with those found in IEC 60079-14 Annex C Initial inspection – Equipment-specific inspection schedules and/or NFPA 70 NEC500 / NEC505

Inspections shall be specific to the Ex protection techniques used.

4.6.7.2 | Specific Inspection Checks



General

- Equipment has been selected & installed appropriately for the area classification requirements based on class division / zone, group, temperature class / max surface temperature, ingress protection, ambient temperature ranges.
- There are no signs or evidence of scratches, dings, pitting, cracks, discoloration, deformations.
- There is no damage or unauthorized modifications.
- There is no evidence of unauthorized modifications.

Cable / Conduit Entries

- Appropriate sealing
- Barrier type cable gland or conduit seal is installed, if applicable.

Terminals

'X' – Specific Conditions of Use

- Specific conditions of use (if applicable) are complied with.

4.6.7.3 | Sample Documentation

Tables C.1, C.2 and C.3 give equipment-specific inspection schedules.

Table C.1 – Inspection schedule for Ex “d”, Ex “e”, Ex “n” and Ex “t”

Check that:		Ex “d”	Ex “e”	Ex “n” Ex “t”
		Grade of Inspection: Detailed		
A	GENERAL (ALL EQUIPMENT)			
1	Equipment is appropriate to the EPL/zone requirements of the location	X	X	X
2	Equipment group is correct	X	X	X
3	Equipment temperature class is correct (only for gas)	X	X	n
4	Equipment maximum surface temperature is correct			t
5	Degree of protection (IP grade) of equipment is appropriate for the level of protection/group/conductivity	X	X	X
6	Equipment circuit identification is correct	X	X	X
7	Equipment circuit identification is available	X	X	X
8	Enclosure, glass parts and glass-to-metal sealing gaskets and/or compounds are satisfactory	X	X	X
9	There is no damage or unauthorized modifications	X	X	X
10	There is no evidence of unauthorized modification			
11	Bolts, cable entry devices (direct and indirect) and blanking elements are of the correct type and are complete and tight			
	– physical check	X	X	X
12	Threaded covers on enclosures are of the correct type, are tight and secured			
	– physical check	X		
13	Joint surfaces are clean and undamaged and gaskets, if any, are satisfactory and positioned correctly	X		
14	Condition of enclosure gaskets is satisfactory	X	X	X
15	There is no evidence of ingress of water or dust in the enclosure in accordance with the IP rating	X	X	X
16	Dimensions of flanged joint gaps are: – within the limits in accordance with the manufacturer’s documentation or – within maximum values permitted by the relevant construction standard at time of installation or – within maximum values permitted by site documentation	X		
17	Electrical connections are tight		X	X
18	Unused terminals are tightened		X	n
19	Enclosed-break and hermetically sealed devices are undamaged			n
20	Encapsulated components are undamaged		X	n
21	Flameproof components are undamaged		X	n
22	Restricted breathing enclosure is satisfactory (type “nR” only)			n

Refer to IEC 60079-14 Annex C Tables C.1, C.2, and C.3

4.6.8 | Pre-Commissioning & Commissioning



Use and Setting-Up;

- Refer to camera manufacturer’s instruction manual, in conjunction with this manual
- Parameters such as electrical values, ambient temperature ranges, maximum surface temperatures, and other limit values shall be review, verified, and documented in an inspection test report.
- Safety Devices shall be verified and validated for settings and correct operation.

4.6.9 | Maintenance

Follow the requirement(s) of:

- IEC 60079-17;
- Section 5.6.1.2 – Preservation;
- Section 5.6.1.3 – Handling and Exposure;

For each maintenance activity, an Ex-Inspection shall be done to the relevant Grade of Inspection (Detailed, Close, Visual). Opening of equipment requires a detailed inspection to be done. Conducting this inspection confirms compliance with Ex safe operation of the equipment and Section 5.6.11 – Periodic Inspections.

4.6.10 | Troubleshooting

Issue	Solution(s)
Signs of damage, discolouration, water ingress into camera (main) housing, modifications, use of non-OEM components	Do not open main housing; Complete an Ex-Inspection report; Contact Manufacturer
Camera not operating	Review troubleshooting instruction in camera manufacturer’s manual
How to clean Dome / Lens	Refer to Section 5.6.1.3 – Handling and Exposure;
Unable to open terminal enclosure	Contact Integrator; Contact Manufacturer



4.6.11 | Periodic Inspections

Ex Inspections shall be carried via Period Inspections, with no greater than 3 years between inspections. Grade of inspection may be visual, close, or detailed. (IEC 60079-14)

Past inspection results shall be available for review by inspector from the Verification Dossier.

Periodic Inspection

inspection of all electrical equipment, systems and installations carried out on a routine basis.

4.6.11.1 | Documentation

Inspections shall be documented via inspection test reports, with support of pictures.

Documentation formats shall comply with those found in IEC 60079-17 Clause 6 Inspection Tables.

Inspections shall be specific to the Ex-protection techniques used, with reference checks to IEC 60079-17 Clause 5 Additional inspection schedule requirements.

4.6.11.2 | Specific Inspection Checks

General

- Equipment has been selected & installed appropriately for the area classification requirements based on class division / zone, group, temperature class / max surface temperature, ingress protection, ambient temperature ranges.
- There shall be no signs or evidence of scratches, dings, pitting, cracks, discolouration, deformations.
- There is no damage or unauthorized modifications.
- There is no evidence of unauthorized modifications.

Cable / Conduit Entries

- Appropriate sealing;
- Barrier type cable gland or conduit seal is installed, if applicable.

'X' – Specific Conditions of Use

- Specific conditions of use (if applicable) are complied with.

4.6.11.3 | Sample Documentation

Table 1 – Inspection schedule for Ex “d”, Ex “e”, Ex “n” and Ex “t/tD”

Check that: X = required for all types, n = type “n” only, t = type “t” and “tD” only		Ex “d”			Ex “e”			Ex “n” Ex “t/tD”		
		Grade of inspection								
		D	C	V	D	C	V	D	C	V
A	GENERAL (ALL EQUIPMENT)									
1	Equipment is appropriate to the EPL/Zone requirements of the location	X	X	X	X	X	X	X	X	X
2	Equipment group is correct	X	X		X	X		X	X	
3	Equipment temperature class is correct (only for gas)	X	X		X	X		n	n	
4	Equipment maximum surface temperature is correct							t	t	
5	Degree of protection (IP grade) of equipment is appropriate for the level of protection/group/conductivity	X	X	X	X	X	X	X	X	X
6	Equipment circuit identification is correct	X			X			X		
7	Equipment circuit identification is available	X	X	X	X	X	X	X	X	X
8	Enclosure, glass parts and glass-to-metal sealing gaskets and/or compounds are satisfactory	X	X	X	X	X	X	X	X	X
9	There is no damage or unauthorized modifications	X			X			X		
10	There is no evidence of unauthorized modifications		X	X		X	X		X	X
11	Bolts, cable entry devices (direct and indirect) and blanking elements are of the correct type and are complete and tight									
	– physical check	X	X		X	X		X	X	
	– visual check			X			X			X
12	Threaded covers on enclosures are of the correct type, are tight and secured									
	– physical check	X	X							
	– visual check			X						
13	Joint surfaces are clean and undamaged and gaskets, if any, are satisfactory and positioned correctly	X								

Refer to IEC 60079-17 Clause 6, Tables 1



4.6.12 | Repair, Overhaul, and Reclamation

The flameproof joints of the equipment are not intended to be repaired. Consult the manufacturer if dimensional information on the flameproof joints is necessary.

The main housing is manufactured in a controlled environment that eliminates moisture at the factory and is only to be opened by the manufacturer's factory certified technicians at an authorized repair facility. Opening of the main housing will void all warranties.

NEVER open the Lens Cover of the "F" Series unless authorized and trained and certified to do so by the manufacturer.

4.6.12.1 | Servicing

Internal parts, components, accessories are not to be removed, replaced, or adjusted without consent of the manufacturer.

4.6.12.2 | Cells and Batteries

Cells and Batteries are **non-serviceable / non-replaceable.**

Consult with the integrator and/or manufacturer.

4.6.13 | Decommissioning

The Equipment contains power source(s) and chemicals that are potentially dangerous to personnel and the environment.



When the equipment has reached its end of life (use, function, or operation), please contact the integrator and/or manufacturer to return to have it safely recycled.

4.6.14 | Training

For Spectrum Camera Solutions training and installer certification please contact Spectrum Camera at:

SPECTRUM CAMERA SOLUTIONS

+1-281-769-8802

sales@spectrumcamera.com , and

support@spectrumcamera.com

8935 Almeda Genoa Rd. Bldg B, Houston, Texas, USA 77075

4.6.15 | Specialty Tools

Refer to General Arrangement Drawing